



**ARMÁRIO MULTIUSO**  
*ARMARIO MULTIUSO*  
*MULTIPURPOSE CABINET*  
**BAM 02**



[www.brvmoveis.com.br](http://www.brvmoveis.com.br)

Rua Fioravante Pozza, 404 - Bairro Maria Goretti - CEP 95707-056 - Bento Gonçalves, RS - Fone/Fax 54 2102.5300

Dimensões/Dimensiones/Dimensions:

L: 675 A: 1860 P: 350

W: 26.57" H: 73.23" D: 13.78"

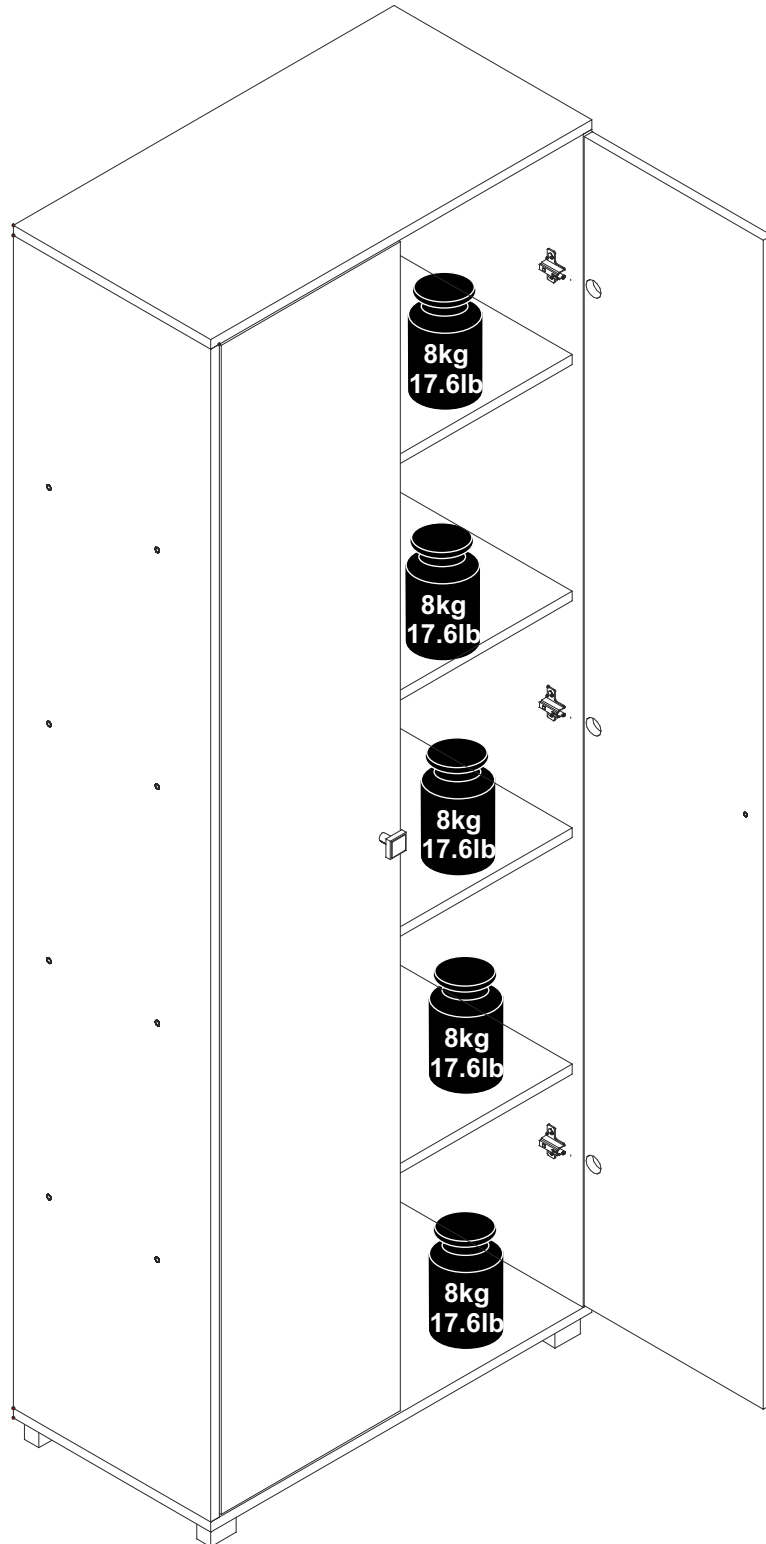

**Antes de iniciar a montagem leia as observações na última página.  
Antes de empezar el montaje, lea las notas de la última página.  
Read the notes on the last page before starting the assembly.**



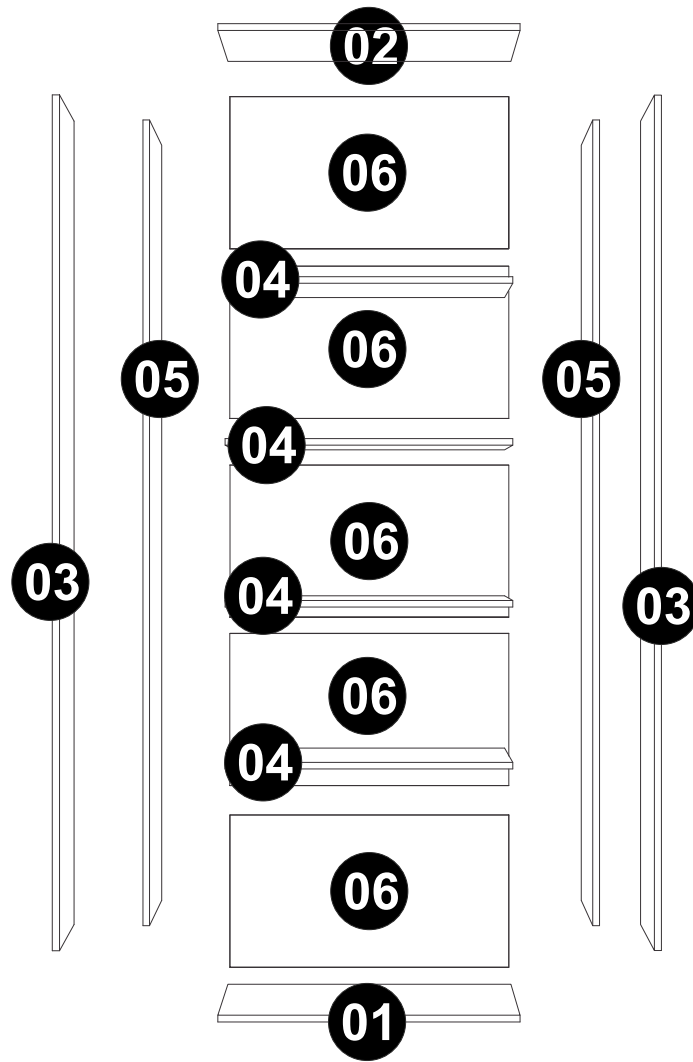



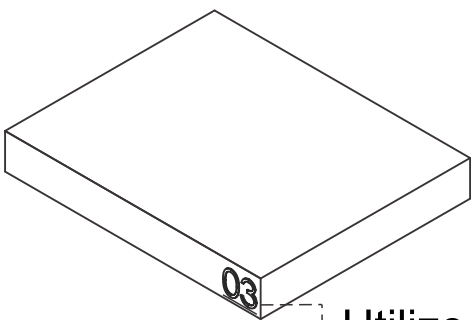







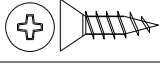

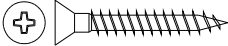

COD.	Descrição/Description/Description	QTD.	mm	in
1-	6419 Base/Base/Base	1	675X350X15	26,57 x 13,78 x 0,59
2-	6420 Tampo/Tapa/Top	1	675X350X15	26,57 x 13,78 x 0,59
3-	6428 Lateral/Lateral/Side	2	1800x350x15	70,87 x 13,78 x 0,59
4-	6429 Prateleira/Repisa/Shelf	4	644x350x15	25,35 x 13,78 x 0,59
5-	6430 Porta/Puerta/Door	2	1794x318x15	70,63 x 12,52 x 0,59
6-	6422 Costas/Dorso/back	5	665X363X2,5	26,18 x 14,29 x 0,10

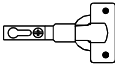

Utilize álcool para retirar os números das peças.  
 Utilice alcohol para sacar los numeros de las piezas.  
 Use alcohol to remove part numbers.

# FERRAGENS/HERRAJE/HARDWARE PARTS

IMAGEM//IMAGEN/PHOTO	CÓDIGO//CODE	QTY.
 8x30	EF 000033	24
 4x50	EF 000132	20
 3,5x14	EF 000106	24
	<b>Tapa-furo</b> <b>Tapas plásticas</b> <b>Adhesive hole plug</b>	16
 <i>Cola/Pegamento/Glue</i>	EF 000008	01
	EF 000168	100
	EF 000169	01
 4x25	EF 000125	08
	<b>Pés retangulares</b> <b>Pies rectangulares</b> <b>Rectangular feet</b>	04
	EF 000025	06
	EF 000043	06
	<b>Puxador/Manilla/Handle</b>	02
 3,5x30	EF 000113	02
	EF 000529	01
	EF 000015	01
 6x50	EF 000246	01

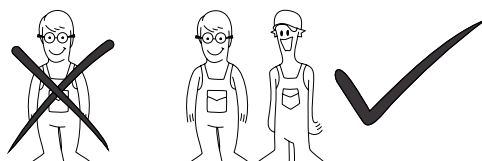
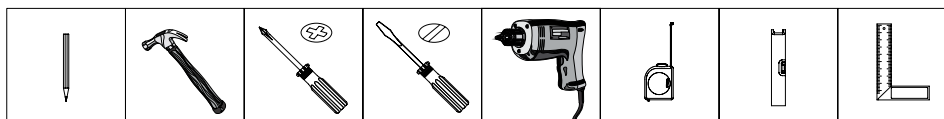

Para facilitar a montagem, utilize uma parafusadeira elétrica.  
Para facilitar el montaje, utilice un destornillador electrónico.  
Electric screwdriver recommended for simple assembly.

Utilize para medir as ferragens.  
Utilice para medir el herraje.  
Use for measuring the hardware.

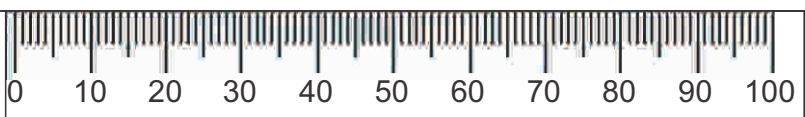

1

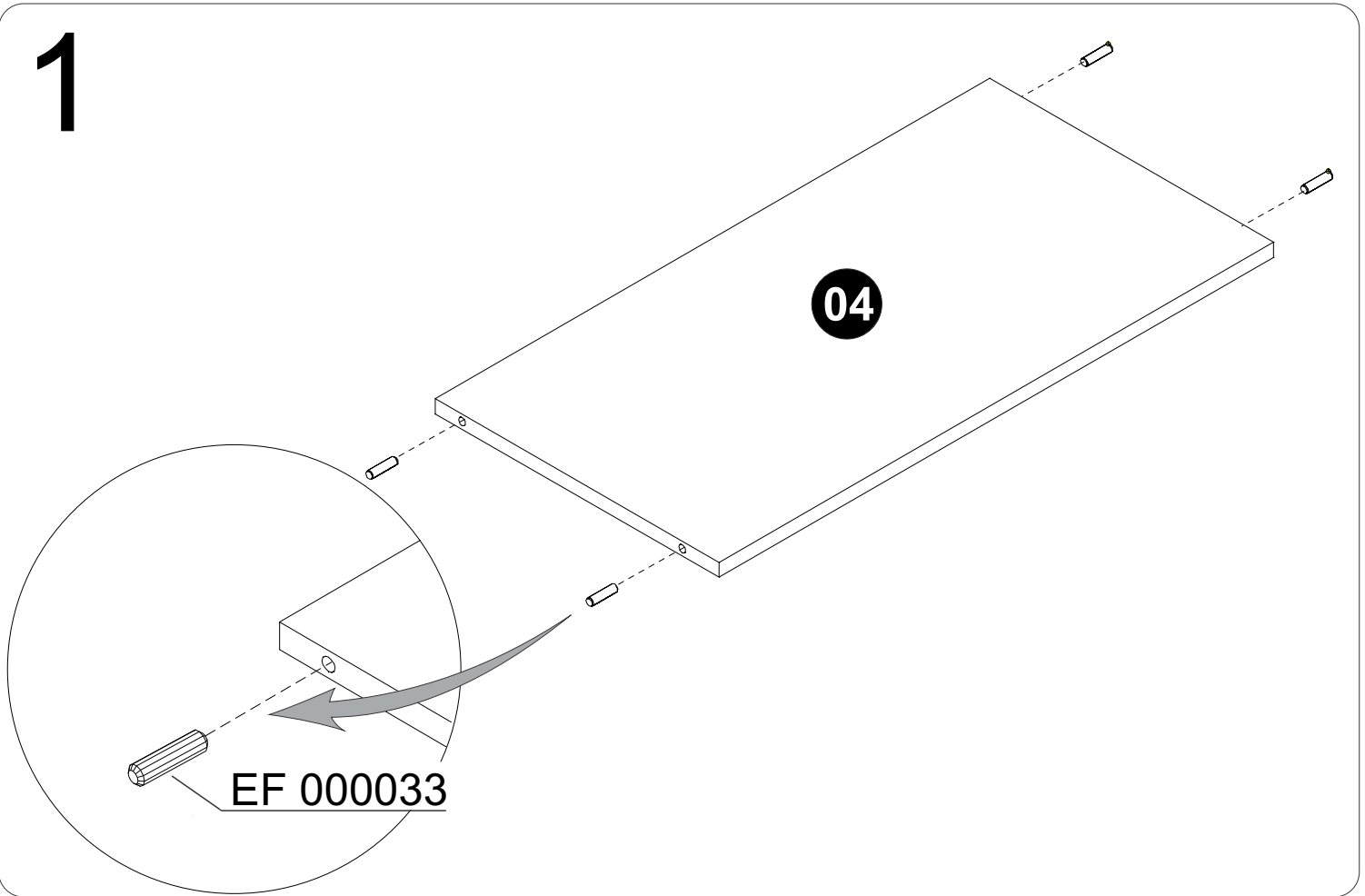

2

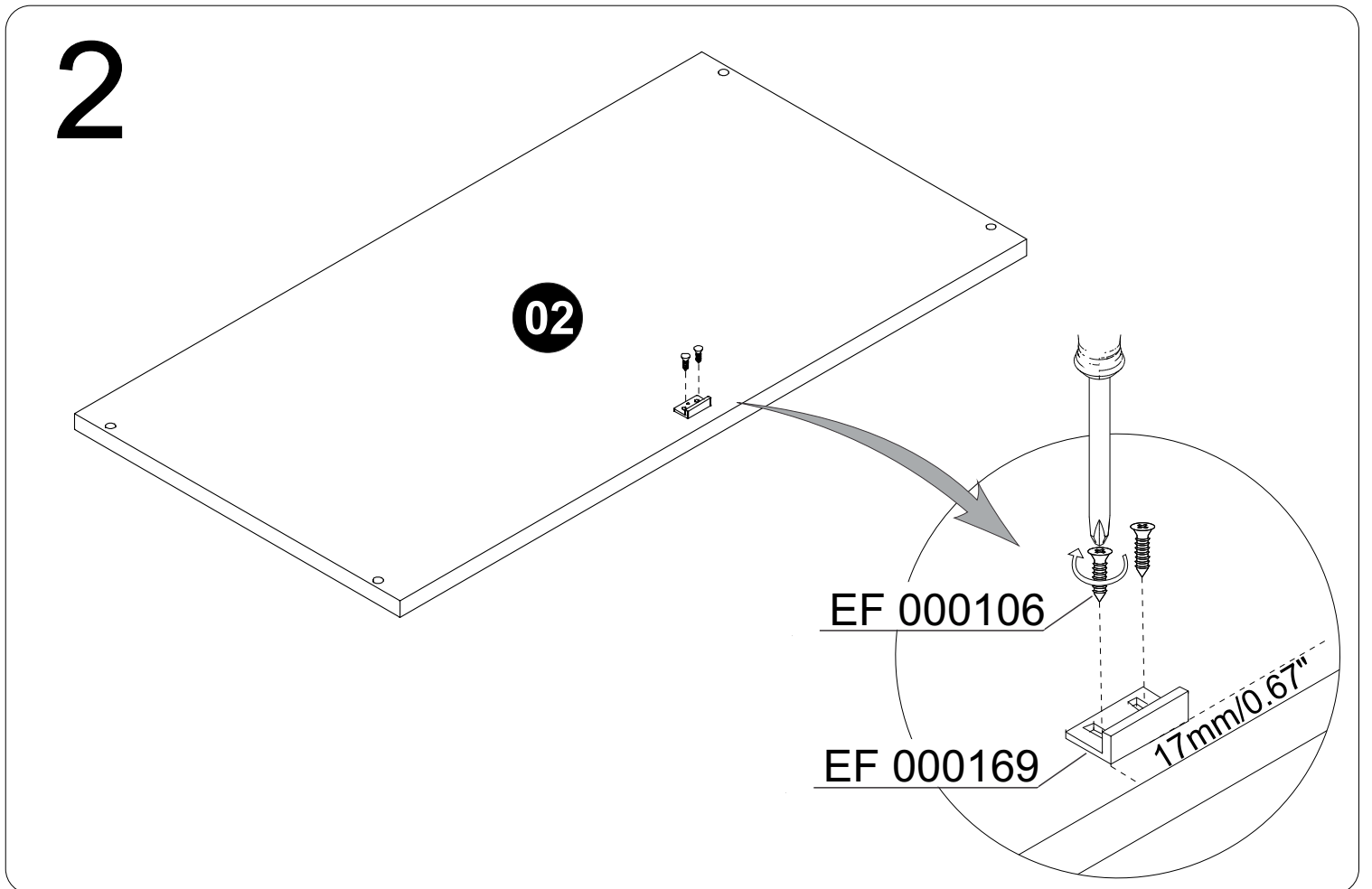

# 3

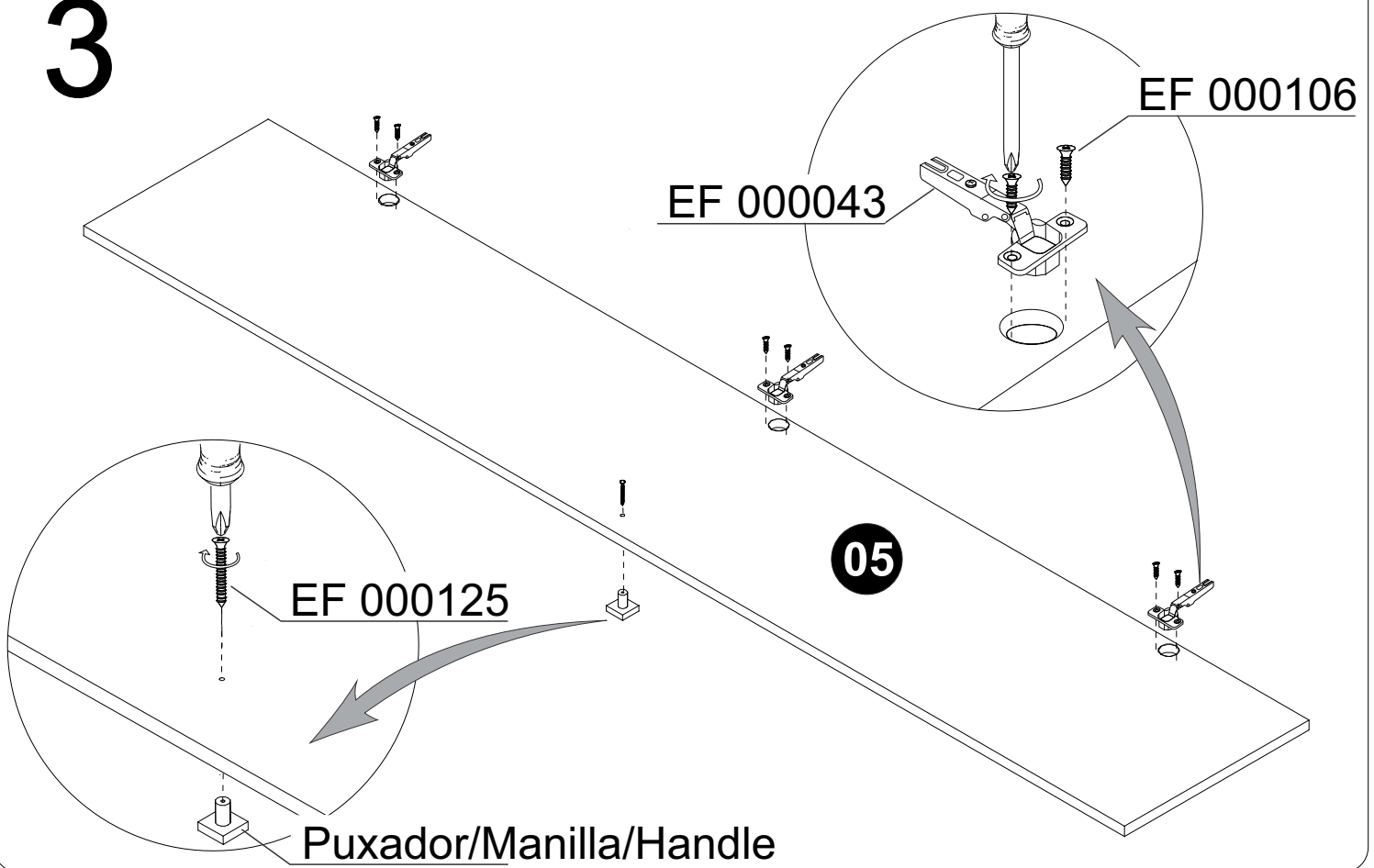

# 4

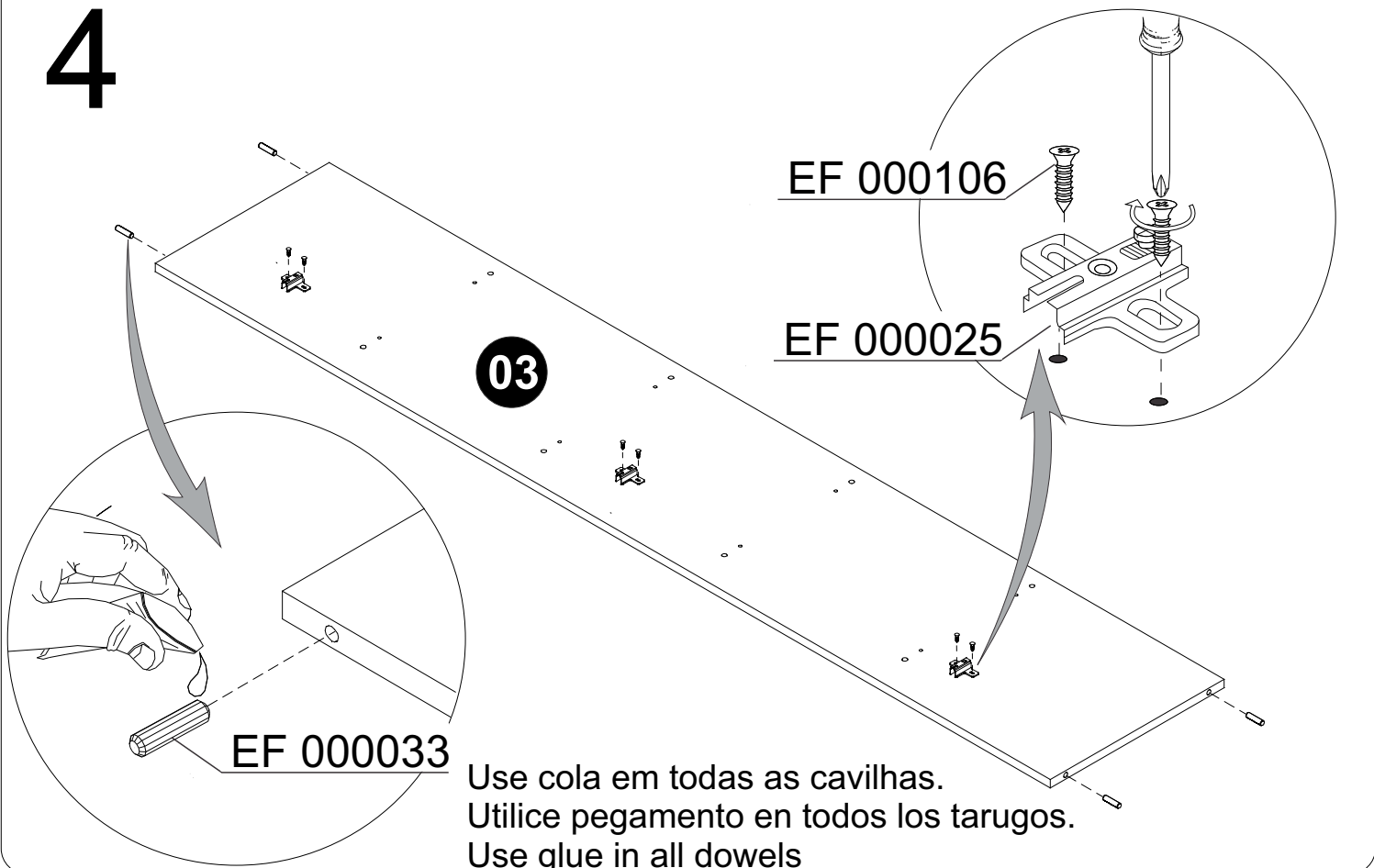

# 5

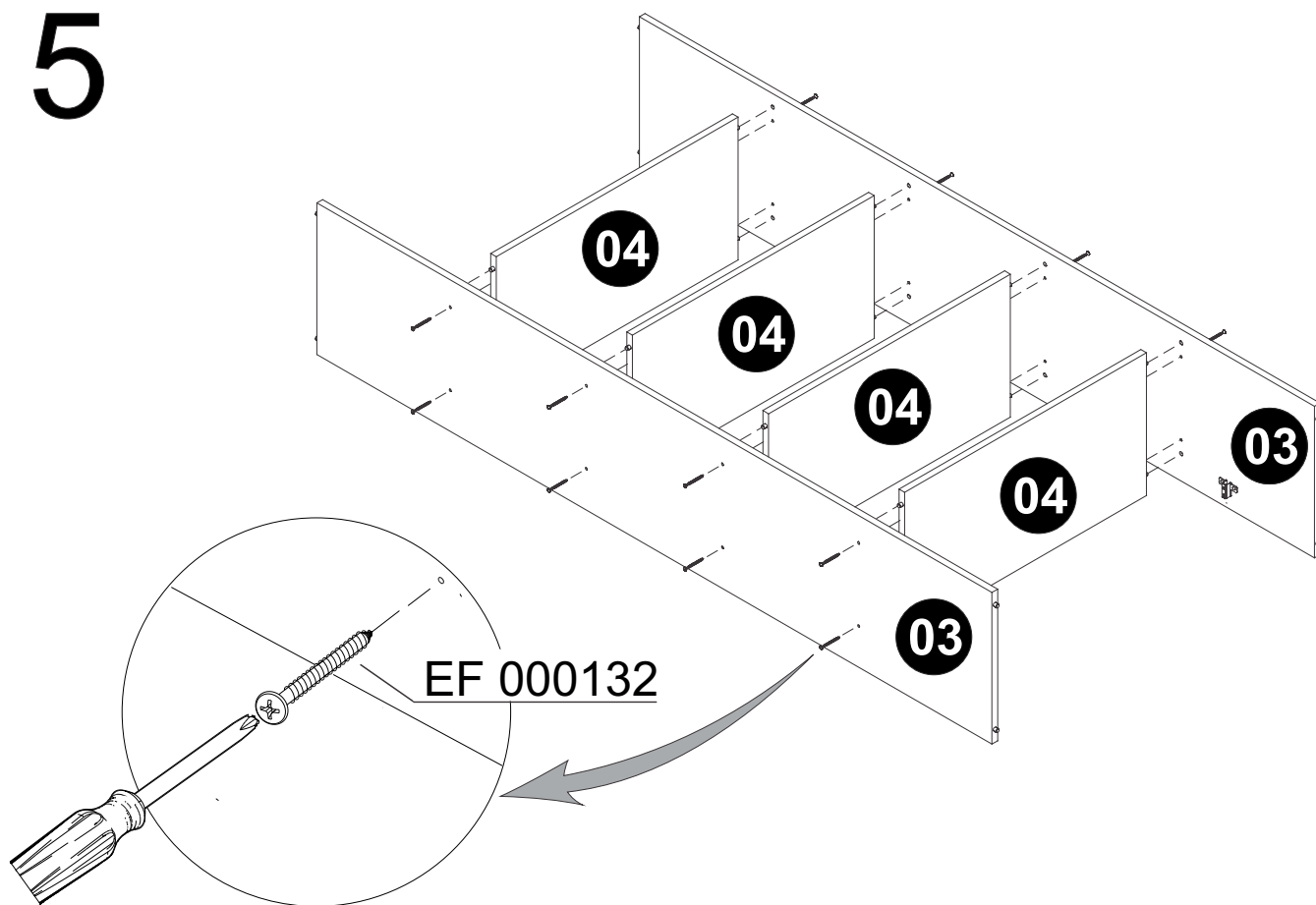

# 6

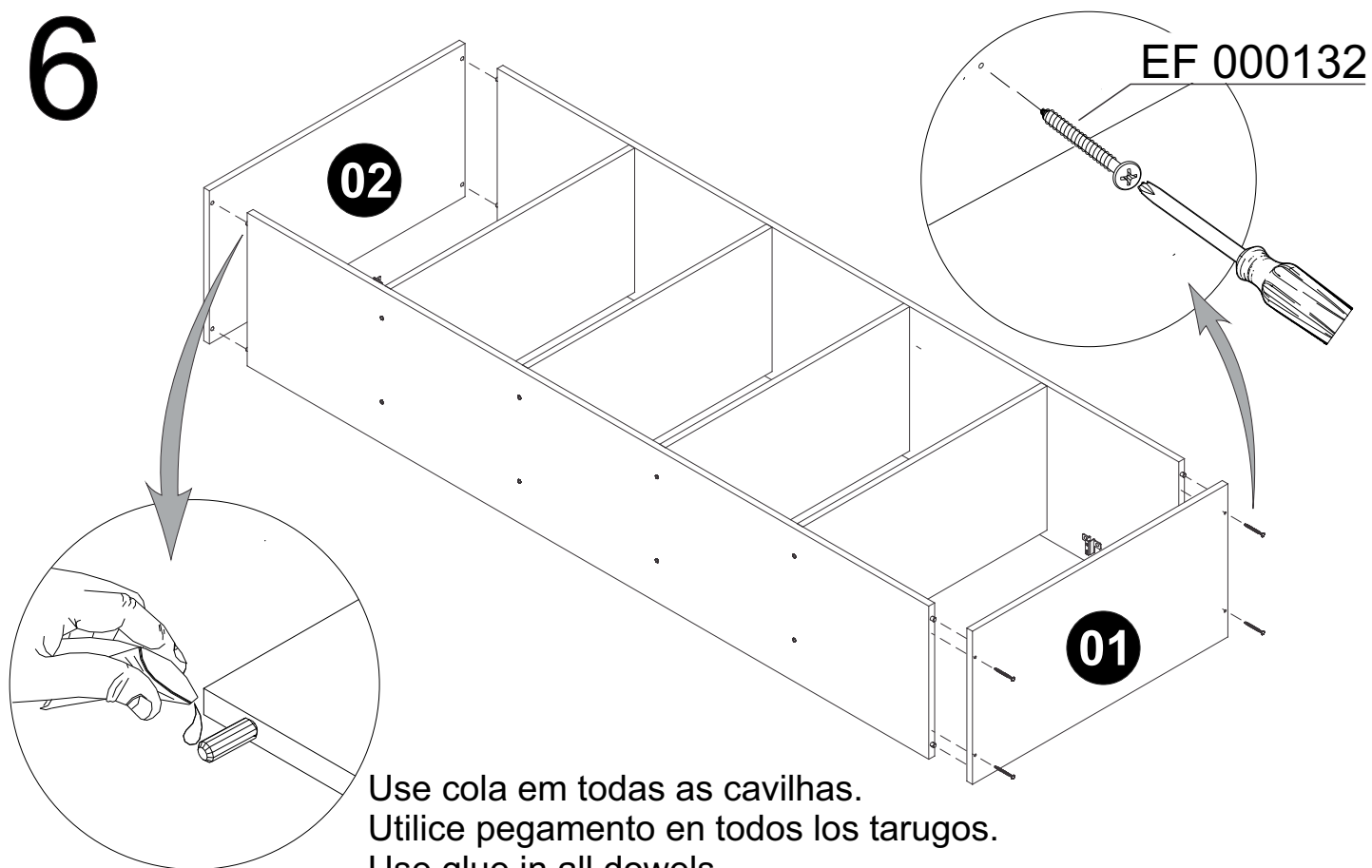

Use cola em todas as cavilhas.  
Utilice pegamento en todos los tarugos.  
Use glue in all dowels

# 7

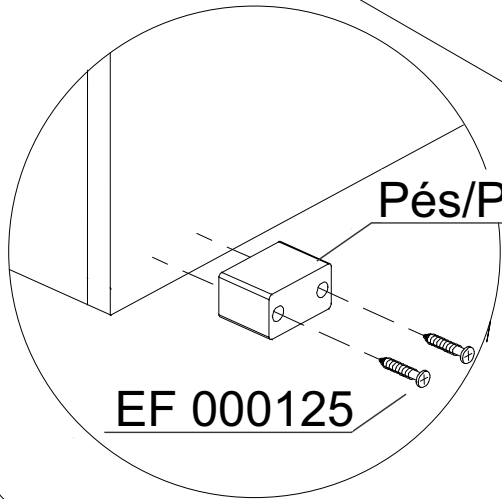

Pés/Pies/Feet

EF 000125

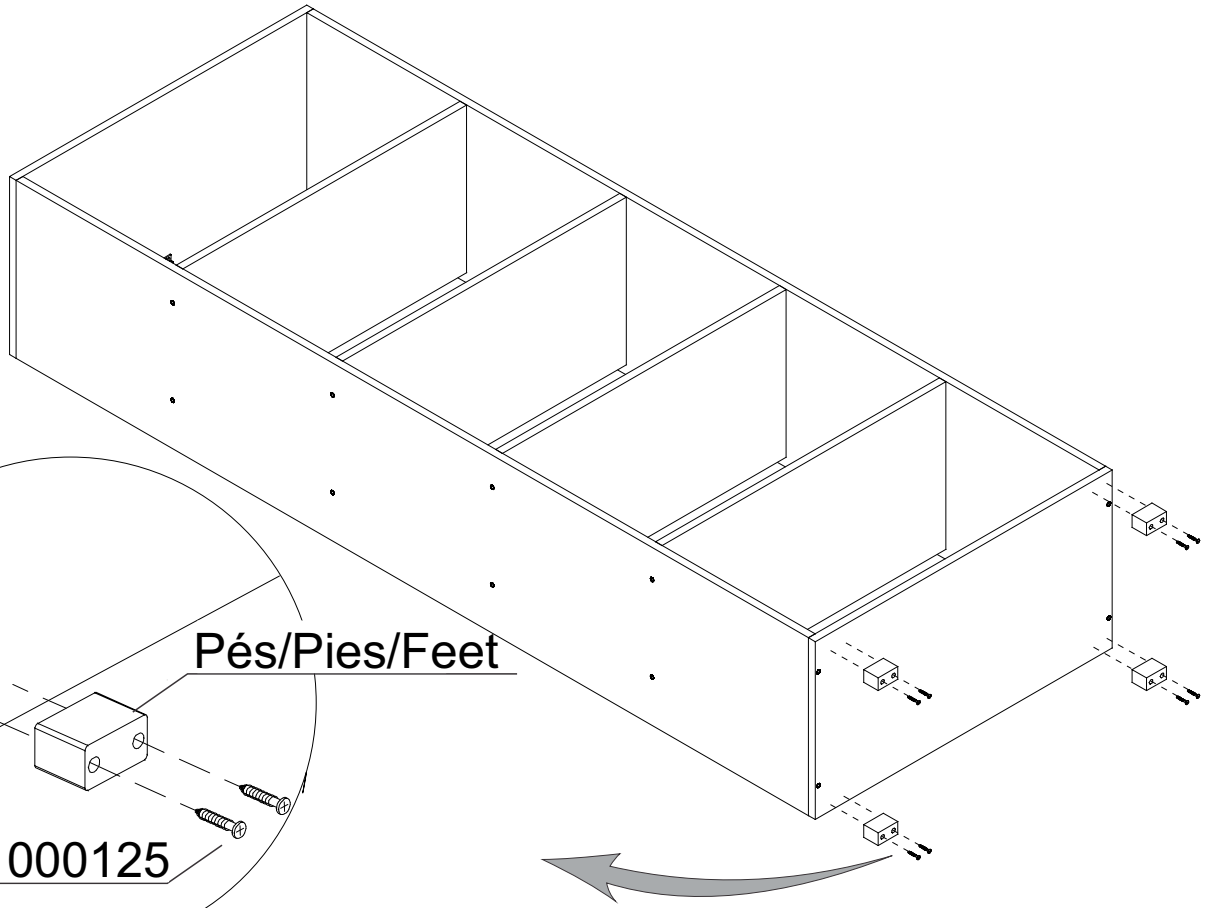

# 8

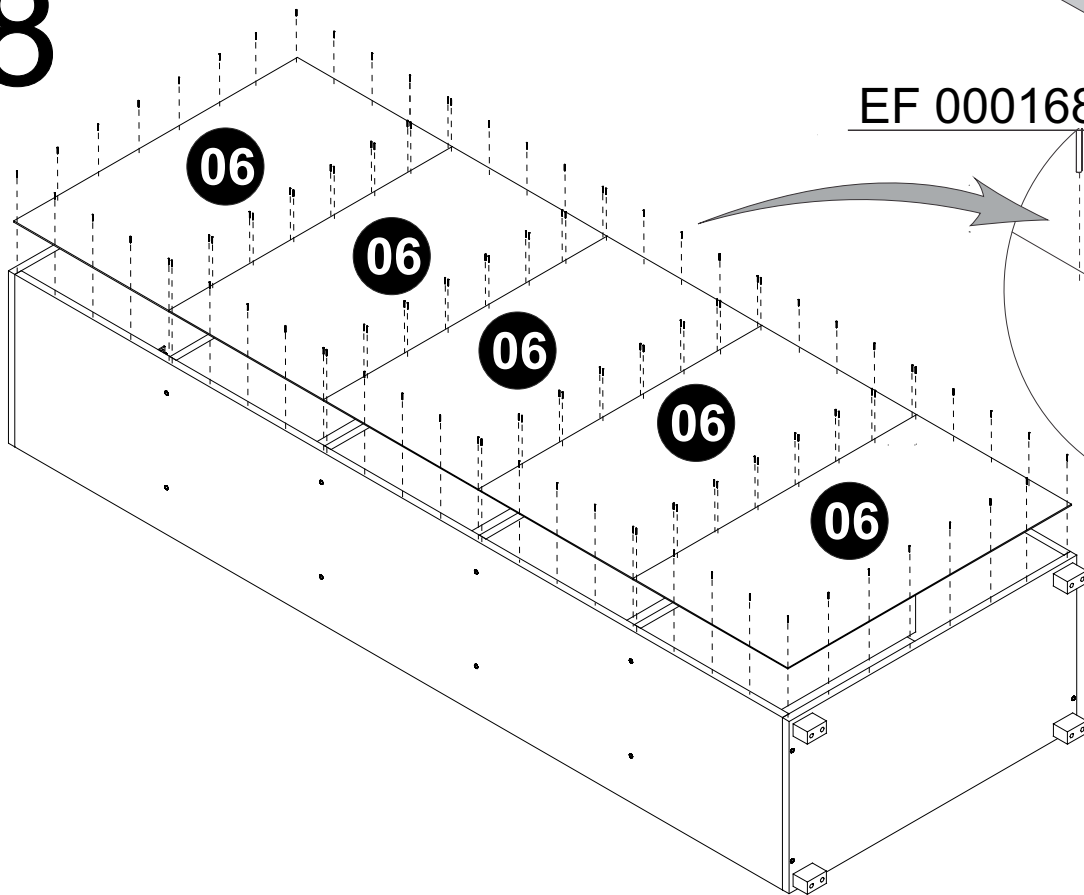

EF 000168

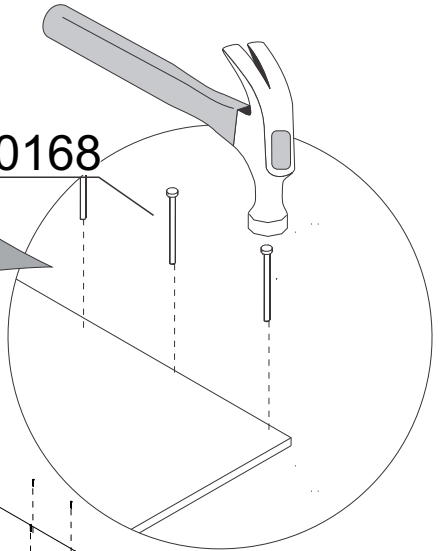



9

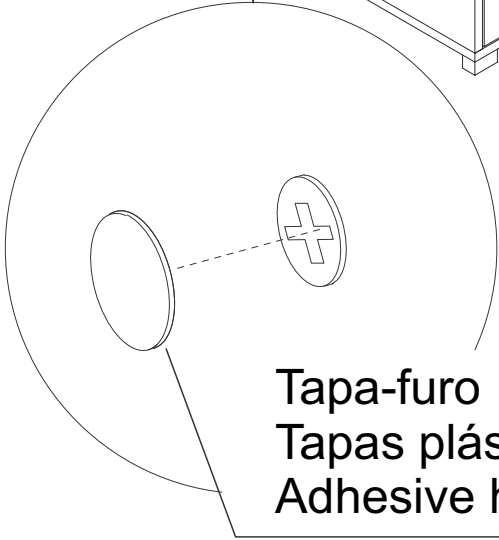
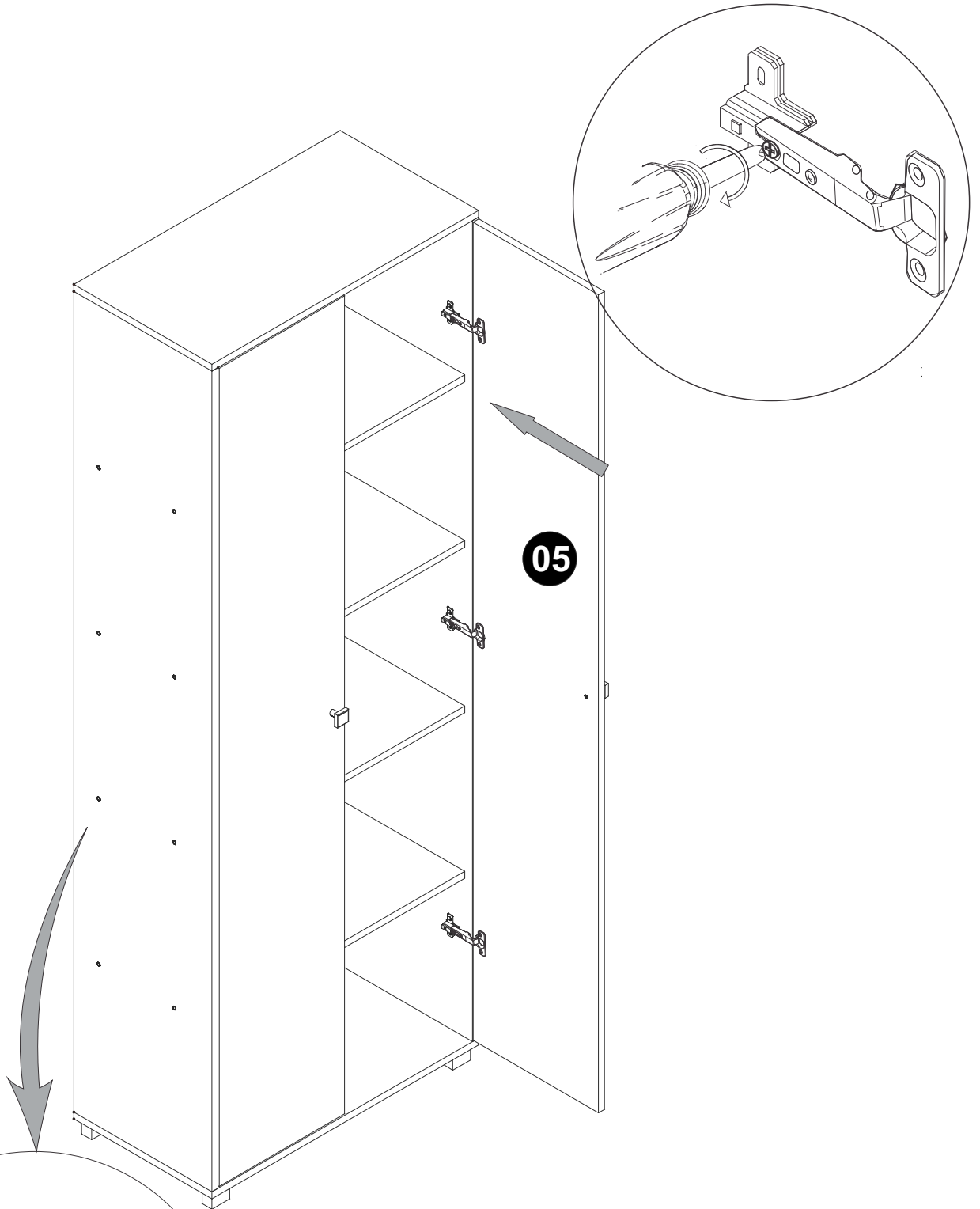

Tapa-furo  
Tapas plásticas  
Adhesive hole plug

# 7



Este produto deve ser fixado na parede, afim de evitar acidentes com crianças  
*Es necesario colgar el producto en la pared para evitar accidentes entre los niños.*  
*This product needs to be fixed on the wall in order to avoid children accident.*

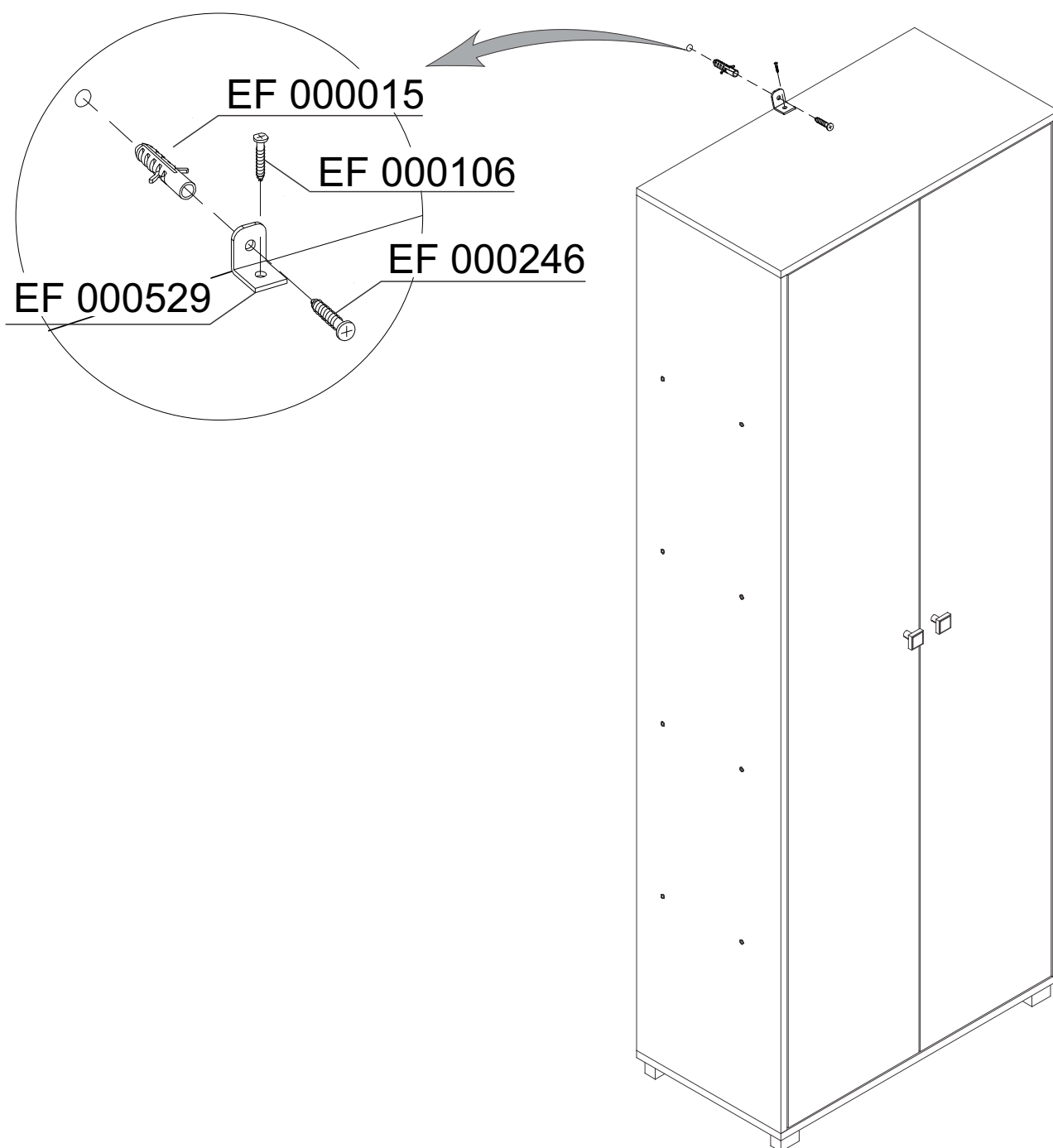

Para garantir a fixação, deixe secar por **8 horas**.  
Para asegurar la fijación, dejar secar durante **8 horas**.  
To ensure the fixing, let dry for **8 hours**.

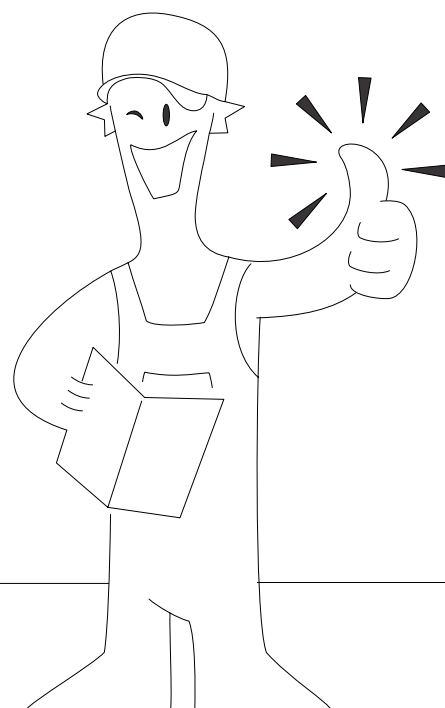
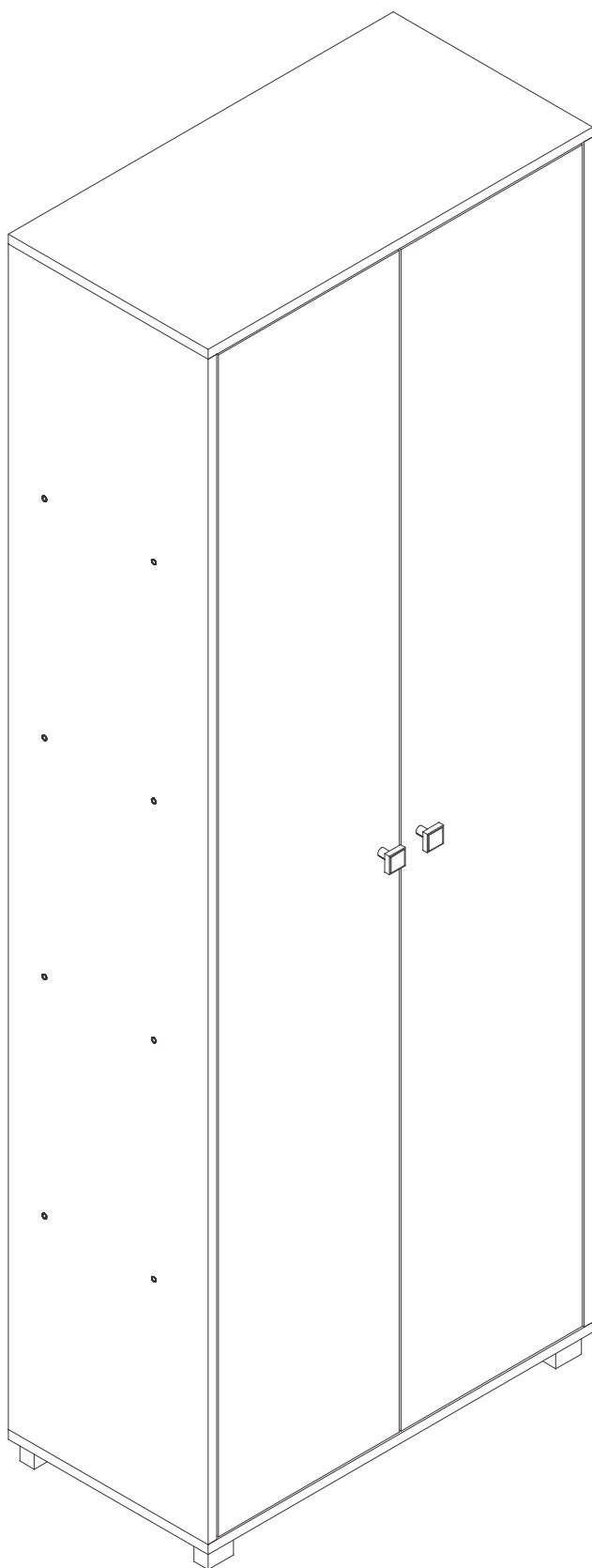

## Atenção!

1. Parabéns, você está adquirindo um produto com a qualidade BRV Móveis.
- 2. Antes de iniciar a montagem leia e observe com atenção este manual.**
3. **IMPORTANTE!** Para que o produto não perca a garantia, solicitamos observar atentamente as orientações de montagem como: fixação do produto na parede, colocação de cola em locais específicos necessários, o peso suportado pelo produto, etc...
4. Caso não sinta segurança em realizar a montagem deste produto, contrate um profissional capacitado.
5. Aconselhamos utilizar a embalagem para forrar o chão, a fim de não danificar o produto.

### Limpeza:

1. Pano levemente umedecido com água, seguido de pano seco.
2. Não utilizar produtos químicos ou abrasivos.
3. Utilizar pano com álcool **SOMENTE** para eliminar a numeração de identificação da peça.

## Atención!

1. Felicitaciones, usted está recibiendo un producto de BRV Muebles.
- 2. Antes de comenzar el montaje, lea estas instrucciones cuidadosamente.**
3. **IMPORTANTE!** Para que el producto no pierda la garantía, pedimos que lea atentamente las instrucciones, principalmente las informaciones de fijación del producto en la pared, colocación de pegamento en local específico y necesario, el peso soportado por el producto etc...
4. Si usted no se siente seguro en hacer el montaje de este producto, póngase en contacto con un profesional.
5. Se recomienda utilizar la caja de cartón para cubrir el piso de tal manera que no se dañe el producto.

### Limpeza:

1. Solamente utilizar un paño húmedo y jabón neutro.
2. No utilice produtos químicos o abrasivos.
3. Utilice un paño con alcohol **SOLAMENTE** para eliminar el número de identificación de la pieza.

## Attention!

1. Congratulations, you're acquiring a product from BRV Móveis.
- 2. Before starting to assemble the product, read and observe carefully this manual.**
3. **IMPORTANT!** In order to keep the guarantee of the product we request you to carefully observe the assembly instructions as: fixing the product on the wall, adding glue in needed and specified places, product weight limit, etc.
4. In case you don't feel confident to assemble this product, contact a professional to do the job.
5. We advise to use the package to protect the floor in order to prevent damages.

### Cleaning:

1. Slightly dampened cloth and after a dry cloth.
2. Do not use chemicals or abrasives.
3. Use alcohol cloth **ONLY** to eliminate part number identification.

#### Garantia (exclusivo para o Brasil/exclusivo de Brasil/exclusive to Brazil):

A garantia dos produtos fabricados pela BRV Móveis, abrange eventuais defeitos-vícios de fabricação, no prazo estabelecido pelo Código de Defesa do Consumidor, em seu artigo 26.II. o qual prevê a garantia de 90 (noventa) dias.



[www.brvmoveis.com.br](http://www.brvmoveis.com.br)

Rua Fioravante Pozza, 404 - Bairro Maria Goretti - CEP 95707-056 - Bento Gonçalves, RS - Fone/Fax 54 2102.5300

