



**MANUAL DE MONTAGEM
ASSEMBLY INSTRUCTIONS
INSTRUCCIONES DE MONTAJE**

COD BR: BMU 27-06

Sumário Summary Resumen

Introdução Introduction Introducción	3
Antes de começar Before starting Antes de comenzar	4
Evite acidentes Avoid accidents Evitar accidentes	4
Dimensões e ferramentas Dimensions and tools Dimensiones y herramientas	5
Identificação das peças Identifying parts Identificación de las piezas	6
Acessórios incluídos na caixa Hardware included in box Accesorios incluidos en la caja	7
Montagem do móvel Furniture assembly Montaje del mueble	8

Introdução Introduction Introducción

Leia atentamente este manual e siga os passos indicados para que o produto não perca a garantia e também para uma perfeita montagem.

Read this manual and follow the steps in order to keep the guarantee and also for the perfect fit.

Lea este manual y siga los pasos para que el producto no pierda la garantía y también para el ajuste perfecto.

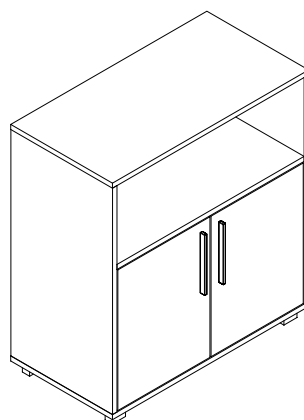

Antes de começar Before starting Antes de comenzar

Antes de começar a montagem prepare o ambiente, deixando-o completamente limpo e com bom espaço para iniciar o trabalho.

Prepare the room before starting the assembly, leaving it completely clean and the area in good condition to start the work.

Antes de comenzar el montaje preparar el ambiente, dejándolo completamente limpio y con bueno espacio para comenzar el trabajo.

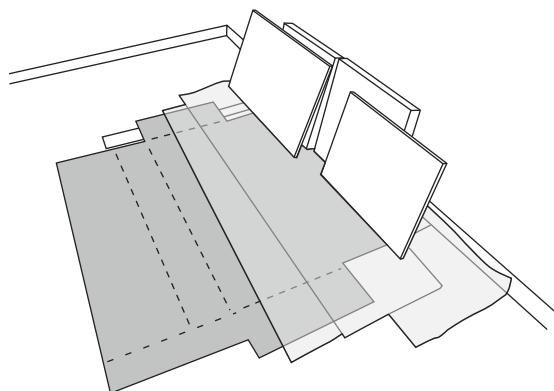

Utilize o papelão da própria embalagem para separar e apoiar as peças retiradas das caixas.

Use the cardboard of the packaging to separate and support the parts removed from the boxes.

Utilice el cartón de la embalaje para separar y apoyar las piezas desmontadas de las cajas.



Forre a área de montagem com um cobertor ou tapete. Assim, você evita avarias nas peças durante o processo de montagem.

Cover the assembly area with a blanket or carpet to avoid damaging the parts during the assembly process.

Cubrir la zona de ensamble con una manta o alfombra. De este modo, se evitan daños en las piezas durante el proceso de montaje.



Evite acidentes Avoid accidents Prevenir accidentes

Solicitamos observar atentamente as orientações de montagem como: fixação do produto na parede, colocação de cola em locais específicos necessários, o peso suportado pelo produto, etc...

We request you to carefully observe the assembly instructions as: fixing the product on the wall, adding glue in needed and specific places, product weight limit, etc.

Pedimos que lea atentamente las instrucciones, principalmente las informaciones de fijación del producto en la pared, colocación de pegamento en local específico y necesario, el peso soportado por el producto etc...

Não escale ou se apoie no móvel.

Do not climb or lean on the furniture.

No se suba ni se apoye en el mueble.

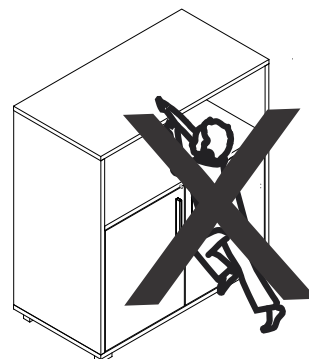

Dimensões e ferramentas
Dimensions and tools
Dimensiones y herramientas

Dimensões:

L: 675 A: 740 P: 294 mm

Dimensions:

W: 26.57 H: 29.13 D: 11.57 inches

Dimensiones:

L: 675 A: 740 P: 294 mm

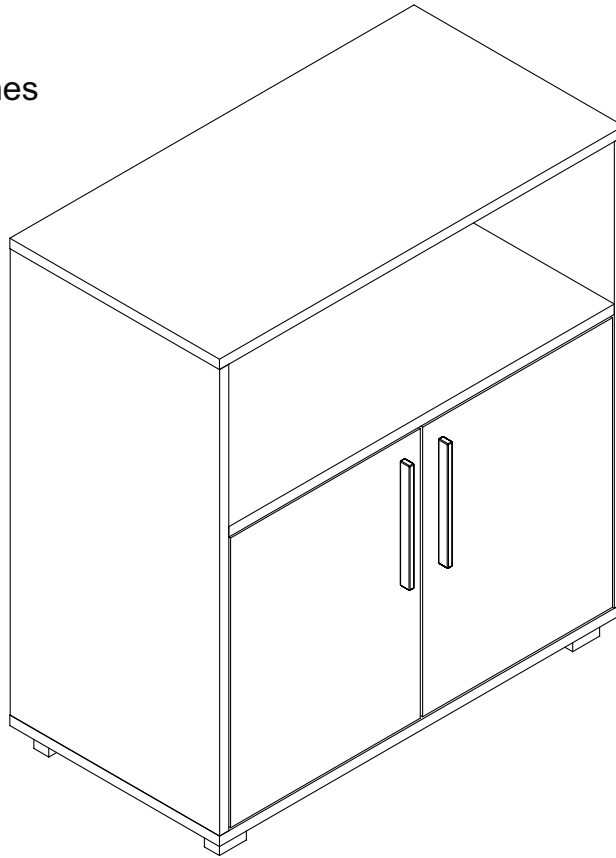

Limpeza
Cleanig
Limpieza

Pano levemente umedecido com água, seguido de pano seco, não utilizar produtos químico ou abrasivos.
Slightly dampened cloth and after a dry cloth, do not use chemicals or abrasives.
Solamente utilizar un paño húmedo y después un paño seco, no utilice productos químicos o abrasivos.

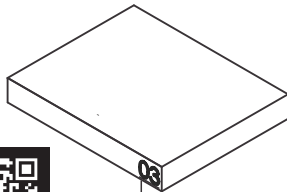

UTILIZE ALCOOL APENAS PARA REMOVER O NUMERO DAS PEÇAS
USE ALCOHOL ONLY TO REMOVE PART NUMBERS
UTILICE ALCOHOL SOLAMENTE PARA ELIMINAR EL NUMERO DE LAS PIEZAS

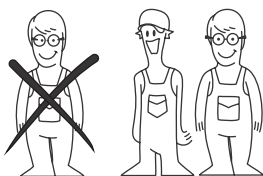

Para facilitar a montagem, utilize uma parafusadeira elétrica.
To improve assembly, use an eletronic screwdriver.
Para facilitar el armado, utilice un destornillador eléctrico.

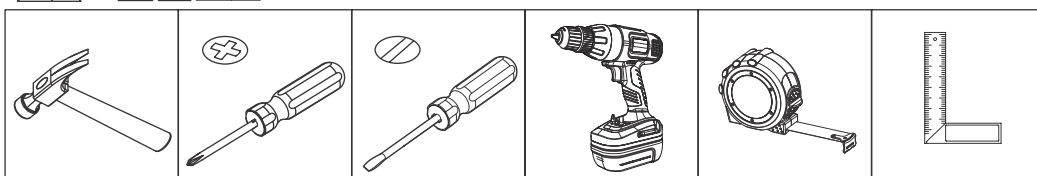

COD BR: BMU 27-06

PEÇA	DESCRIÇÃO	QUANT.	PART DESCRIPTION	QTY	PIEZA	DESCRIPCIÓN	CANTIDAD
001	BASE	1	001 BASE	1	001	BASE	1
002	TAMPO	1	002 TOP	1	002	TAPA	1
003	LATERAL ESQUERDA	1	003 LEFT SIDE	1	003	LATERAL IZQUIERDA	1
004	LATERAL DIREITA	1	004 RIGHT SIDE	1	004	LATERAL DERECHA	1
005	PRATELEIRA	1	005 SHELF	1	005	REPISA	1
006	PORTA ESQUERDA	1	006 LEFT DOOR	1	006	PUERTA IZQUIERDA	1
007	PORTA DIREITA	1	007 RIGHT DOOR	1	007	PUERTA DERECHA	1
008	COSTA	2	008 BACK	2	008	REVÉS	2

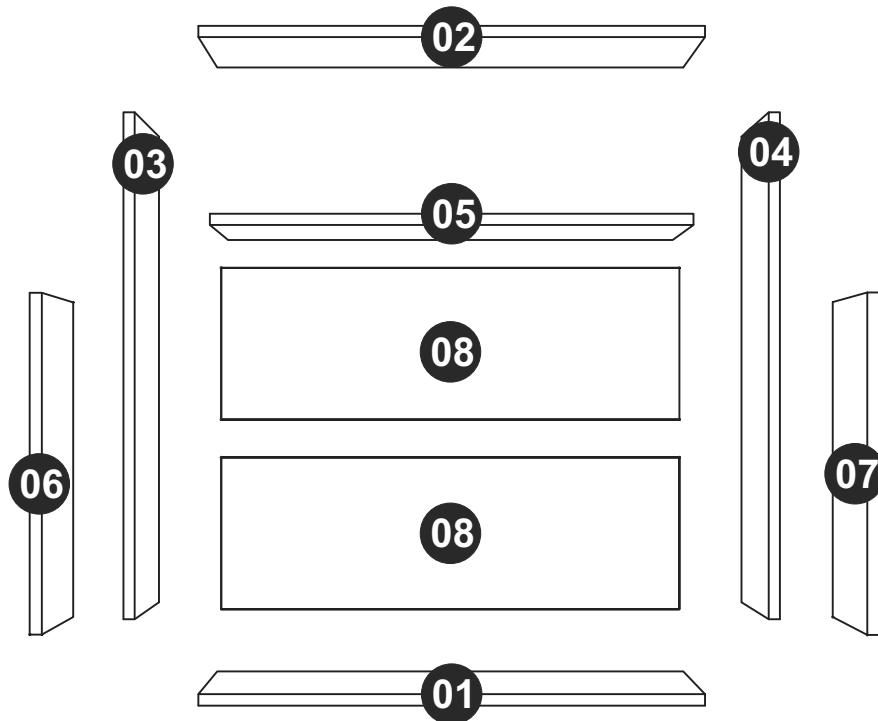

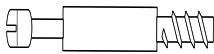

EF 000094 X 8



GIZ x 01
CHALK x 01
TIZA x 01



EF 000216 X 8



EF 000033 x 12
8x30

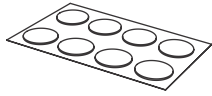

TAPA FUROS x 8
STICKER x 8
TAPAS PLÁSTICAS x 8



EF 000106 X 16
3,5X14 CC



EF 000168 X 24
10X10 C/C

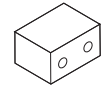

PÉS x 4
FEET x 4
PIES x 4

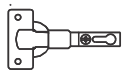

EF 000043 X 4



EF 000025 X 4



EF 000132 x 4
4X50 CC

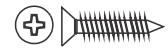

EF 000404 x 12
3,5X25 CC

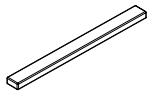

PUXADOR x 2
HANDLE x 2
MANIJA x 2



PERFIL PLASTICO x 1
PLASTIC PROFILE x 1
PERFIL PLASTICO x 1



SUPORTE PLÁSTICO x 2
PLASTIC SUPPORT x 2
SOPORTE PLASTICO x 2

Utilize para medir as ferragens.

Utilice para medir el herraje.

Use for measuring the hardware.

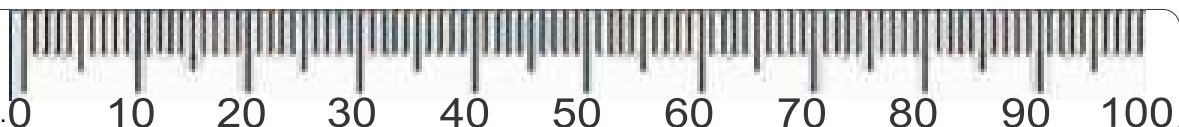

Garantia (exclusivo para o Brasil/exclusivo de Brasil/exclusive to Brazil):

A garantia dos produtos fabricados pela BRV Móveis, abrange eventuais defeitos-vícios de fabricação, no prazo estabelecido pelo código de Defesa do Consumidor, em seu artigo 26.II. o qual prevê a garantia de 90 (noventa) dias.

A = 8KG - 17.63LB

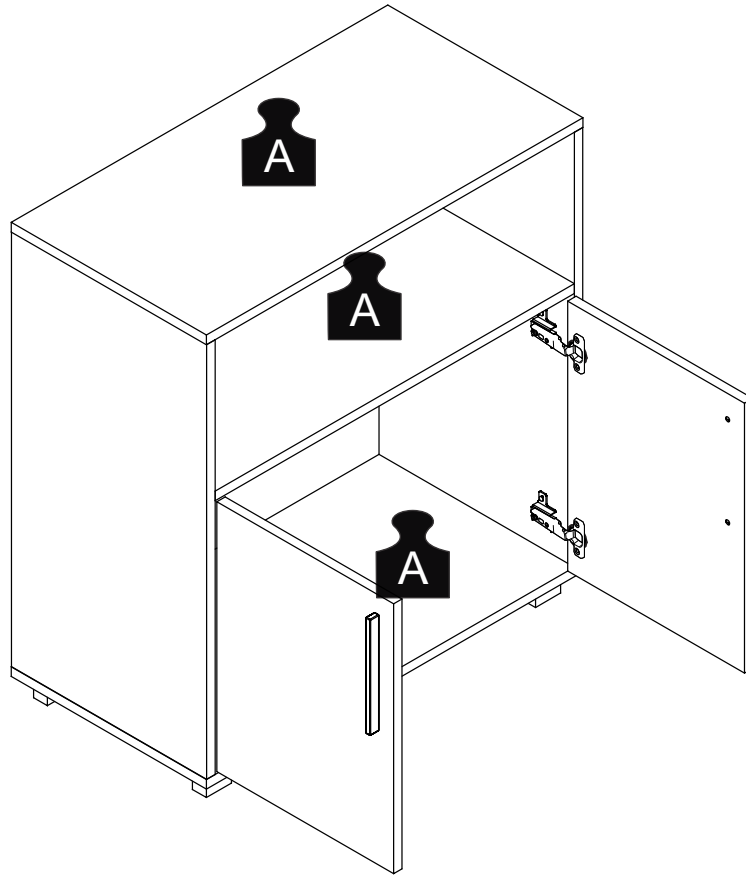

PASSO 1 / STEP 1 / PASO 1

Insira a ferragem EF 000094 nas peças 02, 03 e 04.
Insert hardware EF 000094 into pieces 02, 03 and 04.
Añade el herraje Ef000094 en las piezas 02, 03 y 04.

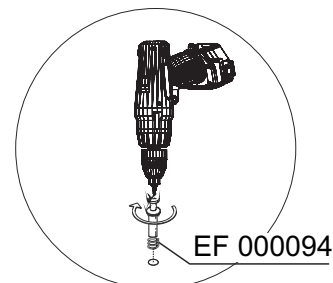
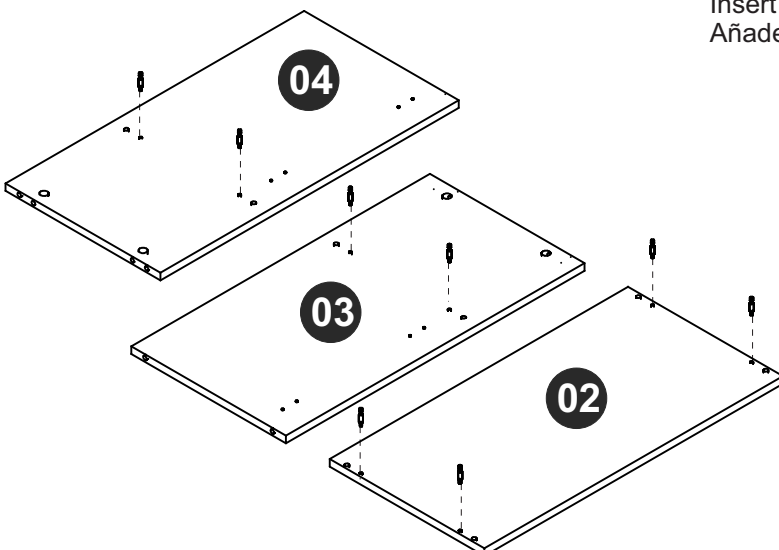

PASSO 2 / STEP 2 / PASO 2

Insira o suporte plástico a ferragem EF 000033 na peça 05.
Insert the plastic support and hardware EF 000033 into piece 05.
Añade el soporte plástico y el herraje EF 000033 en la pieza 05.

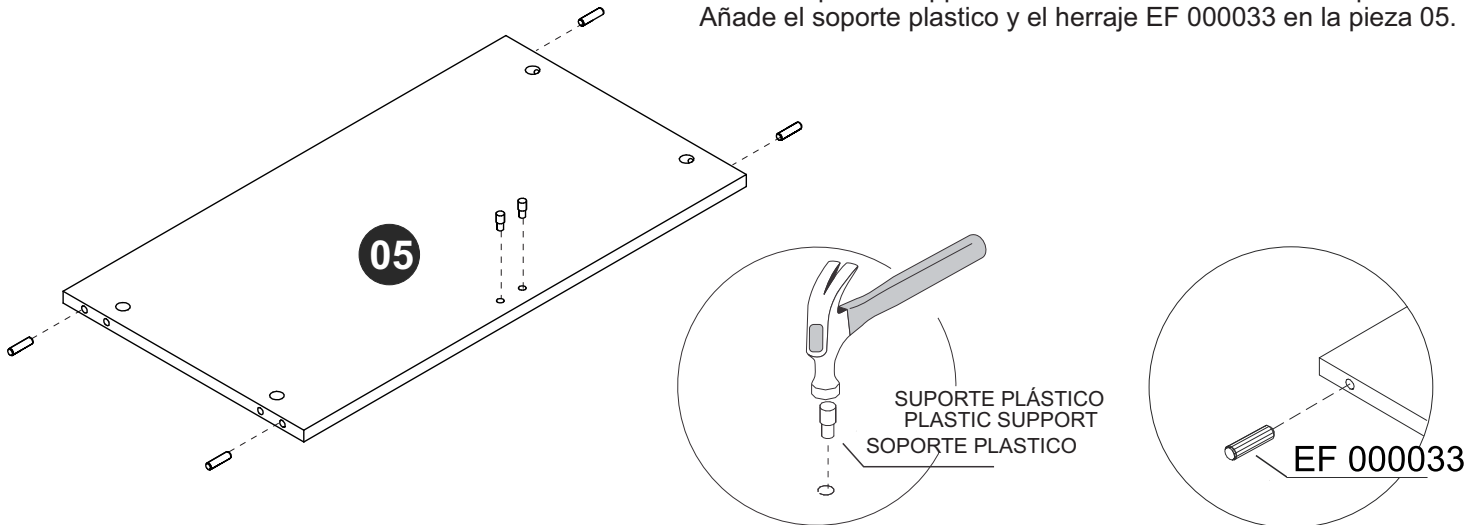

PASSO 3 / STEP 3 / PASO 3

Fixe a ferragem EF 000025 nas peças 03 e 04 utilizando a ferragem EF 000106.
Insira a ferragem EF 000033.
Attach hardware EF 000025 at pieces 03 and 04 using hardware EF 000106.
Insert hardware EF 000033.
Fije el herraje EF 000025 en las piezas 03 y 04 utilizando el herraje EF 000106.
Añade el herraje EF 000033.

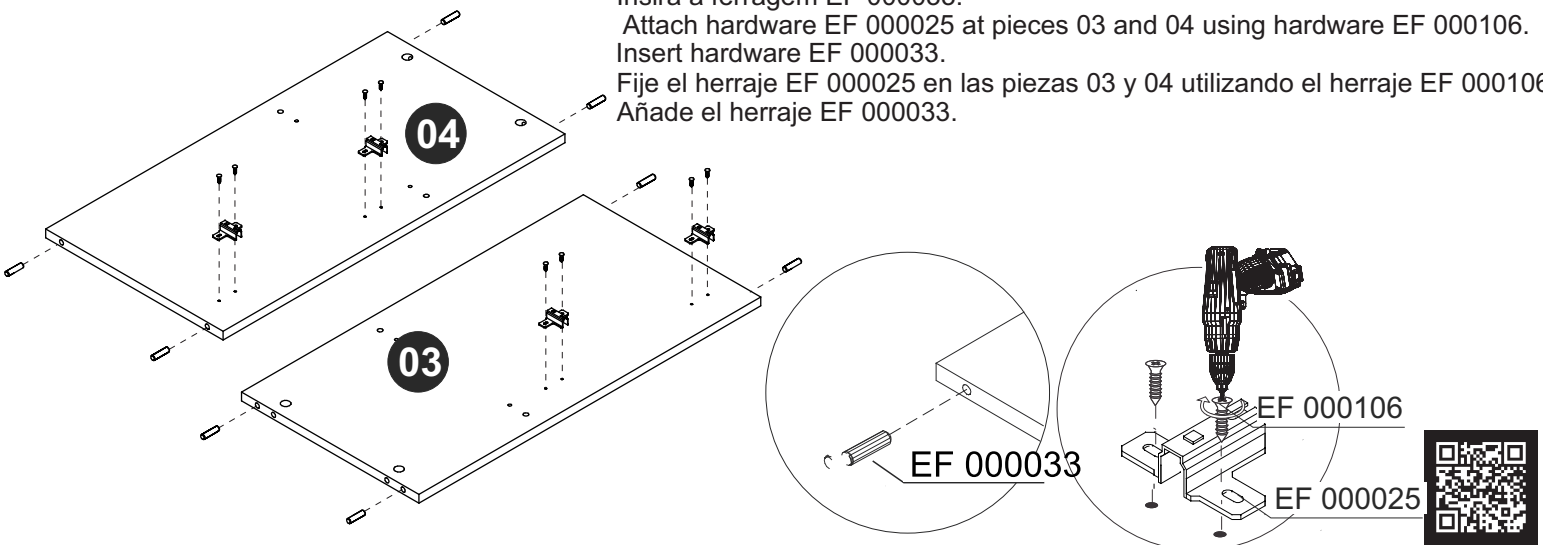

PASSO 4 / STEP 4 / PASO 4

Fixe a ferragem EF 000043 nas peças 06 e 07 utilizando a ferragem EF 000106.
Attach hardware EF 000043 on pieces 06 and 07 using hardware EF 000106.
Fije el herraje EF 000043 en las piezas 06 y 07 utilizando el herraje EF 000106.

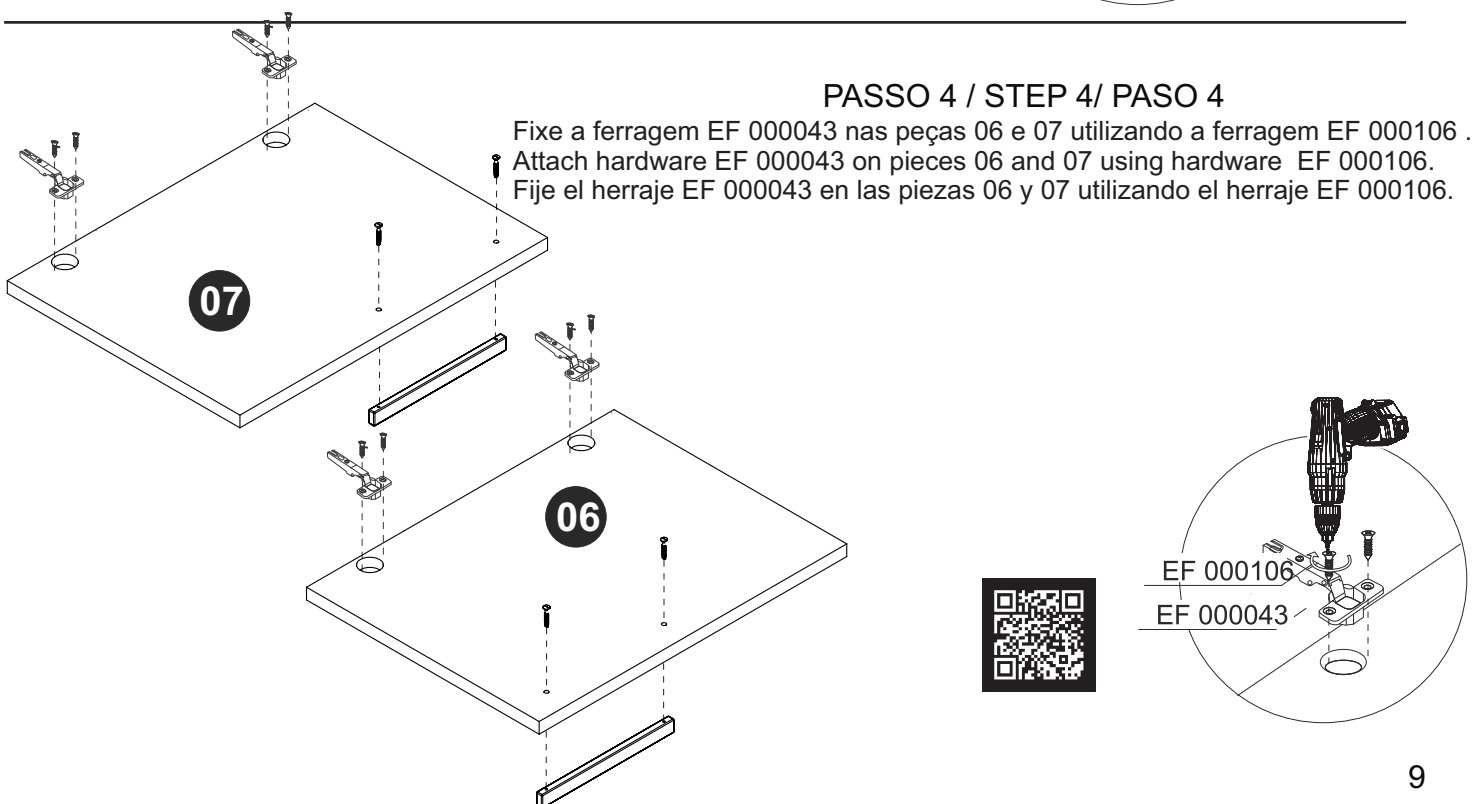

PASSO 5 / STEP 5 / PASO 5

Conecte as peças 03, 04 e 05, insira a ferragem EF 000216 e gire para apertar.
Connect pieces 03, 04 and 05, insert hardware EF 000216 and turn to tighten.
Junte las piezas 03, 04 y 05, añade el herraje EF 000216 y gire para apretar.

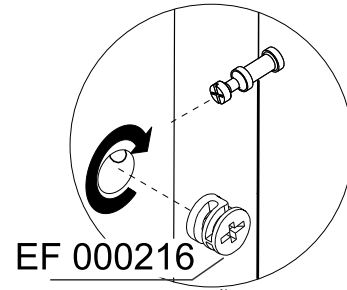
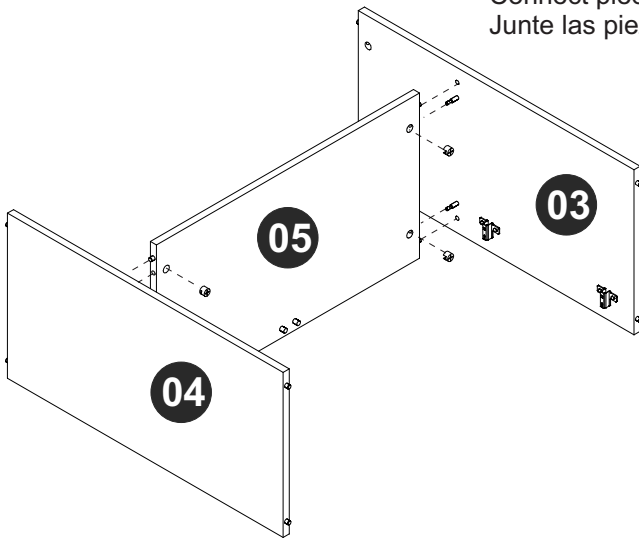

PASSO 6 / STEP 6 / PASO 6

Conecte a peça 02, insira a ferragem EF 000216 e gire para apertar.
Connect piece 02, insert hardware EF 000216 and turn to tighten.
Junte la pieza 02, añade el herraje EF 000216 y gire para apretar.

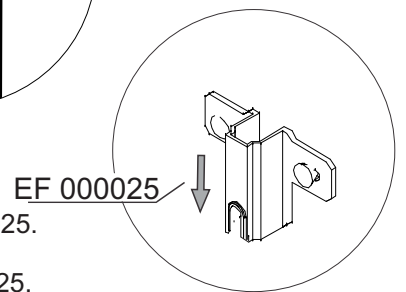
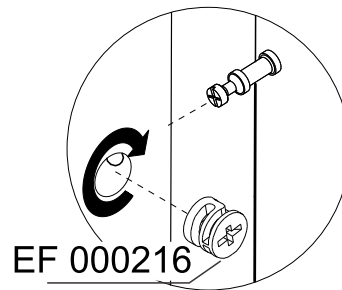
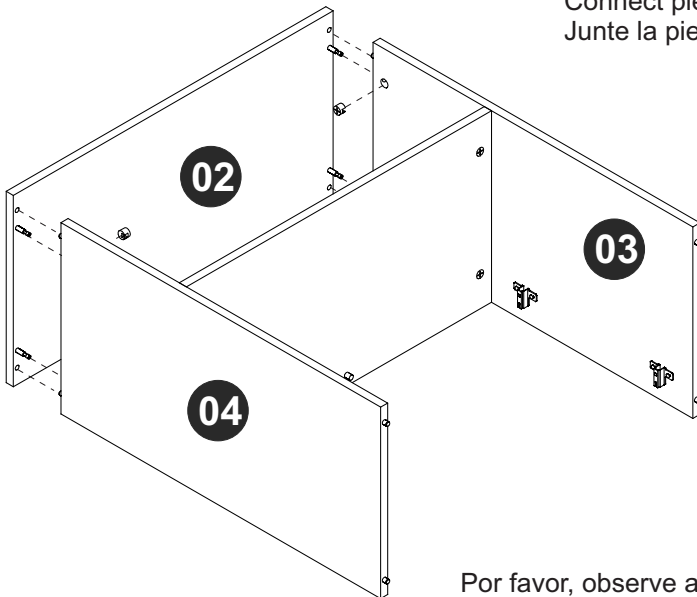

Por favor, observe a posição da ferragem EF 000025.
Please, note hardware EF 000025 position.
Por favor, observe la posición del herraje EF 000025.

PASSO 7 / STEP 7 / PASO 7

Conecte a peça 01 utilizando ferragem EF 000132.
Connect piece 01 using hardware EF 000132.
Junte la pieza 01 utilizando el herraje EF 000132.

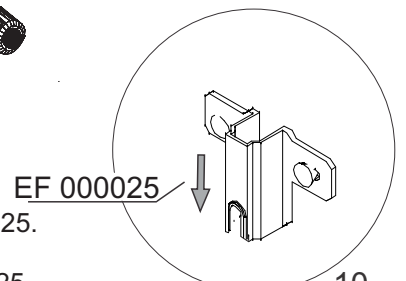
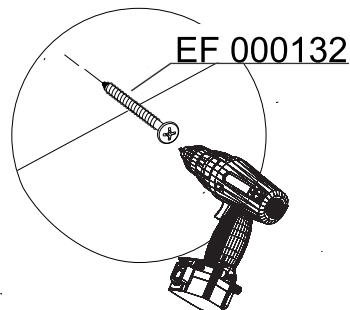
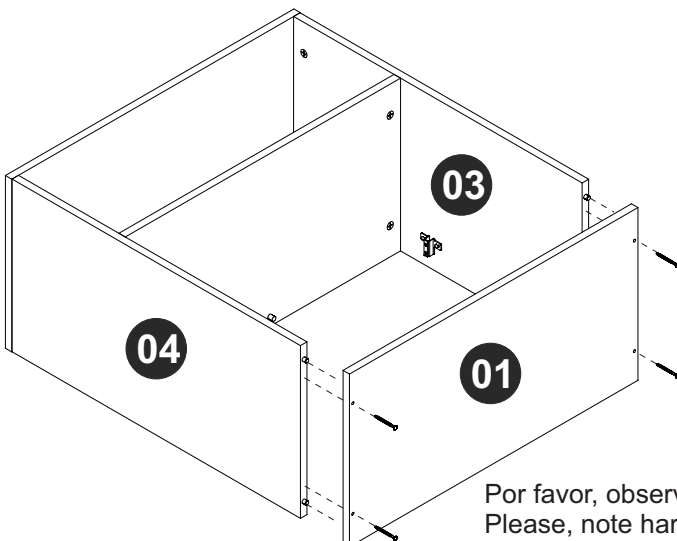

Por favor, observe a posição da ferragem EF 000025.
Please, note hardware EF 000025 position.
Por favor, observe la posición del herraje EF 000025.

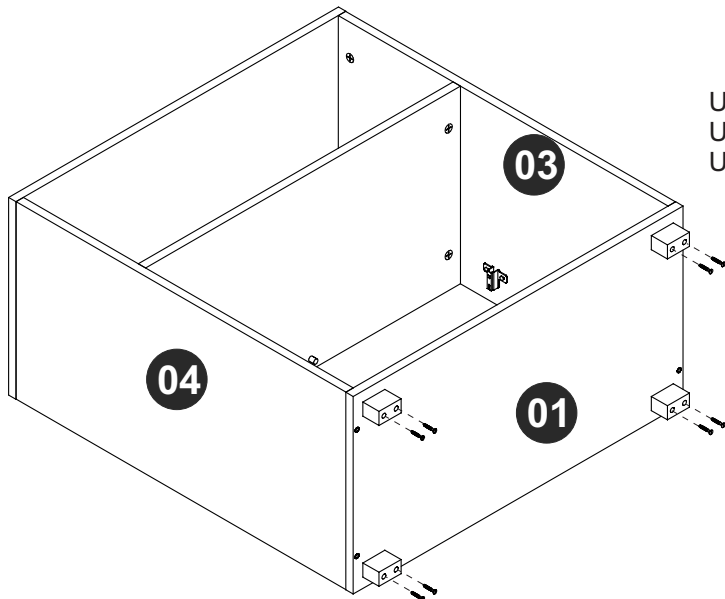

PASSO 8 / STEP 8 / PASO 8

Utilize a ferragem EF 000404 para fixar os pés.
 Use hardware EF 000404 to attach the feet.
 Utilice el herraje EF 000404 para fijar los pies.

PÉS RETANGULARES
 RECTANGULAR FEET
 PIES RECTANGULARES

EF 000404

EF 000025

Por favor, observe a posição da ferragem EF 000025.
 Please, note hardware EF 000025 position.
 Por favor, observe la posición del herraje EF 000025.

PASSO 9 / STEP 9 / PASO 9

Use o perfil plástico para unir as peças 08 e fixe ao móvel utilizando a ferragem EF 000168.

Use the plastic profile to join pieces 08, attach to the furniture using hardware EF 000168.

Utilice el perfil plástico para juntar las piezas 08, fije al mueble utilizando el herraje EF 000168.

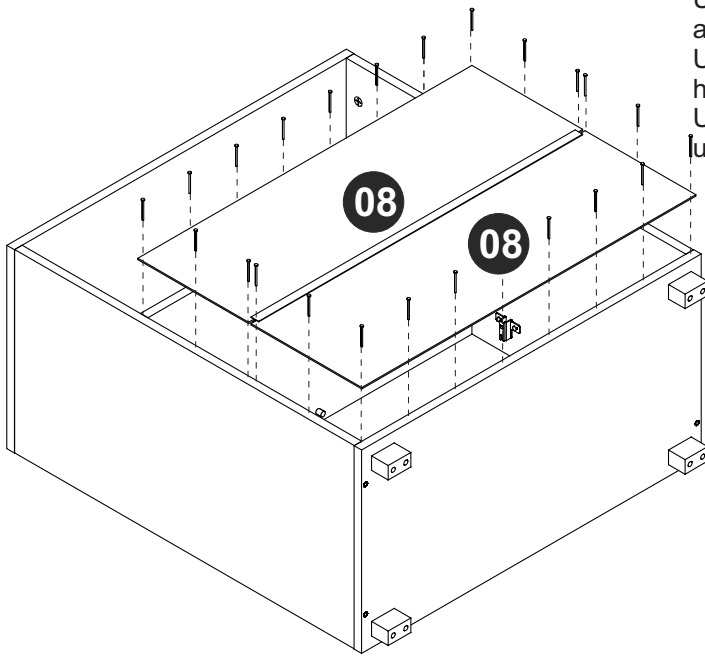

EF 000168

PERFIL PLÁSTICO
 PLASTIC PROFILE
 PERFIL PLASTICO

PASSO 10 / STEP 10 / PASO 10

Fixe as peças 06 e 07 ao móvel montado.

Fix pieces 06 and 07 at the assembled furniture.

Fije las piezas 06 y 07 al mueble armado.

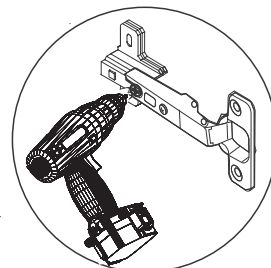
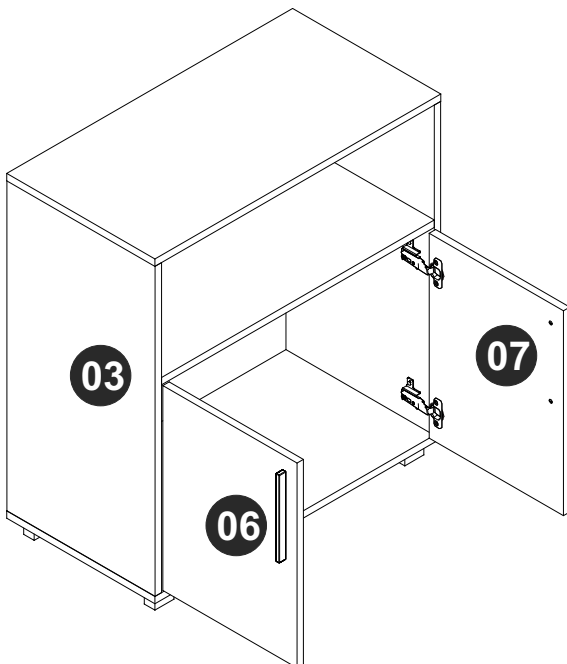

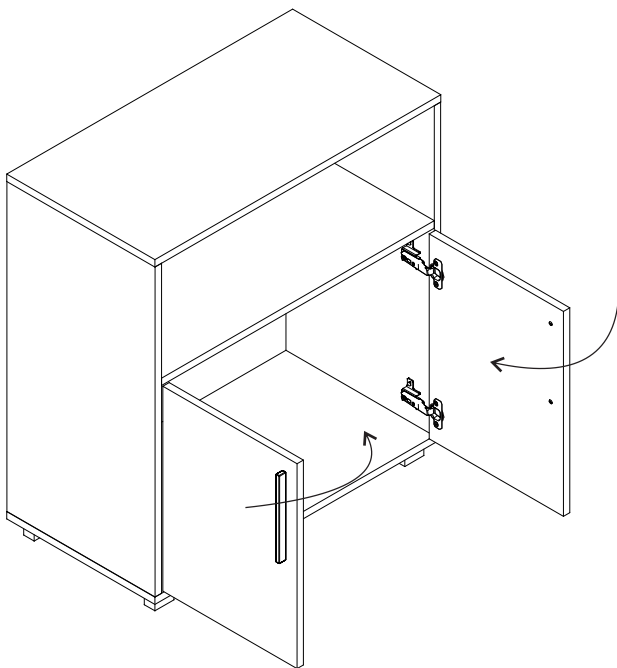

PASSO 11 / STEP 11 / PASO 11
Utilize o tapa furos para cobrir os parafusos aparentes.
Use the sticker to cover the apparent screws.
Utilice los tapa huecos para cubrir los tornillos aparentes.

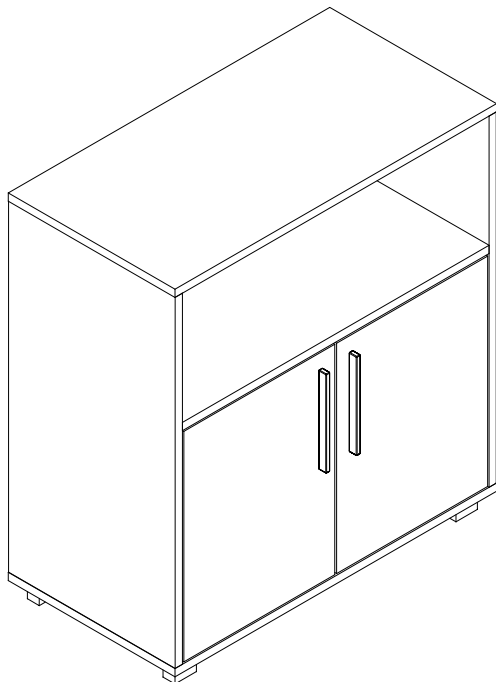
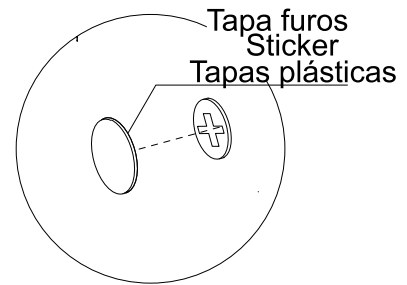

PASSO 12 / STEP 12 / PASO 12
Utilize o giz para dar o acabamento final ao produto.
Use the chalk to give the final finish on the product.
Utilize la tiza para dar el acabado final al producto.

